

CORRECTED VERSION

(19) World Intellectual Property Organization
International Bureau



(43) International Publication Date
9 November 2000 (09.11.2000)

PCT

(10) International Publication Number
WO 00/66856 A1

(51) International Patent Classification⁷: E04F 15/04

Tony [SE/SE]; Skepparegatan 41, S-114 52 Stockholm (SE).

(21) International Application Number: PCT/SE00/00785

(74) Agent: AWAPATENT AB; P.O. Box 5117, S-200 17 Malmö (SE).

(22) International Filing Date: 26 April 2000 (26.04.2000)

(25) Filing Language: Swedish

(81) Designated States (*national*): AE, AG, AL, AM, AT, AT (utility model), AU, AZ, BA, BB, BG, BR, BY, CA, CH, CN, CR, CU, CZ, CZ (utility model), DE, DE (utility model), DK, DK (utility model), DM, DZ, EE, EE (utility model), ES, FI, FI (utility model), GB, GD, GE, GH, GM, HR, HU, ID, IL, IN, IS, JP, KE, KG, KP, KR, KR (utility model), KZ, LC, LK, LR, LS, LT, LU, LV, MA, MD, MG, MK, MN, MW, MX, NO, NZ, PL, PT, RO, RU, SD, SE, SG, SI, SK, SK (utility model), SL, TJ, TM, TR, TT, TZ, UA, UG, US, UZ, VN, YU, ZA, ZW.

(26) Publication Language: English

(30) Priority Data:
9901574-5 30 April 1999 (30.04.1999) SE

(71) Applicant (*for all designated States except US*):
VÄLINGE ALUMINIUM AB [SE/SE]; Kyrkogränd 1, S-260 40 Viken (SE).

(84) Designated States (*regional*): ARIPO patent (GH, GM, KE, LS, MW, SD, SL, SZ, TZ, UG, ZW), Eurasian patent (AM, AZ, BY, KG, KZ, MD, RU, TJ, TM), European patent (AT, BE, CH, CY, DE, DK, ES, FI, FR, GB, GR, IE, IT, LU,

(72) Inventors; and
(75) Inventors/Applicants (*for US only*): PERVAN, Darko [SE/SE]; Kyrkogränd 1, S-260 40 Viken (SE). PERVAN,

[Continued on next page]

(54) Title: LOCKING SYSTEM, FLOORBOARD COMPRISING SUCH A LOCKING SYSTEM, AS WELL AS METHOD FOR MAKING FLOORBOARDS

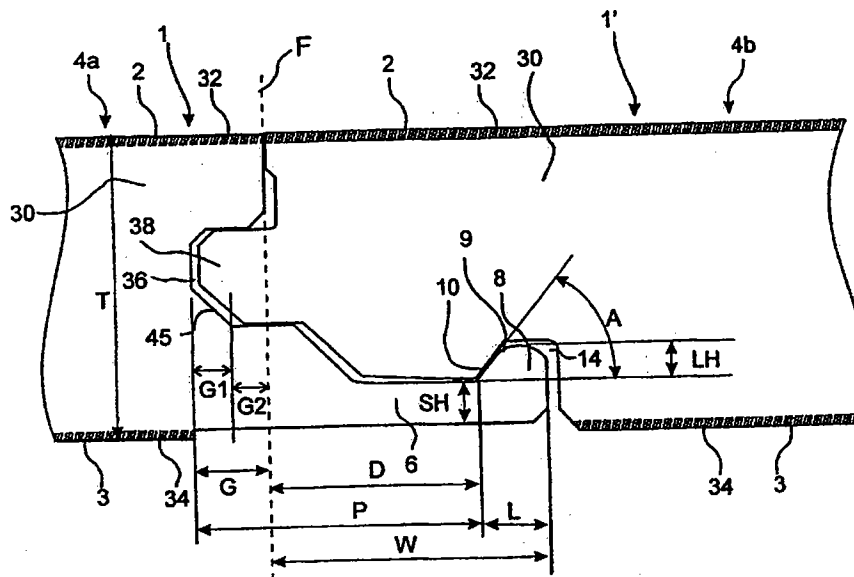

(57) Abstract: The invention relates to a locking system for mechanical joining of floorboards (1) constructed from a body (30), a rear balancing layer (34), and an upper surface layer (32). A strip (6), which is integrally formed with the body (30) of the floorboard and which projects from a joint plane (F) and under an adjoining board (1), has a locking element (8) which engages a locking groove (14) in the rear side of the adjoining board. The joint edge provided with the strip (6) is modified with respect to the balancing layer (34), for example by means of machining of the balancing layer under the strip (6), in order to prevent deflection of the strip (6) caused by changes in relative humidity. The invention also relates to a floorboard provided with such a locking system, as well as a method for making floorboards with such a locking system.

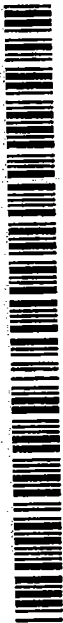

WO 00/66856 A1



MC, NL, PT, SE), OAPI patent (BF, BJ, CF, CG, CI, CM, GA, GN, GW, ML, MR, NE, SN, TD, TG).

(15) Information about Correction:

see PCT Gazette No. 37/2001 of 13 September 2001, Section II

Published:

— *with international search report*

(48) Date of publication of this corrected version:

13 September 2001

For two-letter codes and other abbreviations, refer to the "Guidance Notes on Codes and Abbreviations" appearing at the beginning of each regular issue of the PCT Gazette.

LOCKING SYSTEM, FLOORBOARD COMPRISING SUCH A LOCKING
SYSTEM, AS WELL AS METHOD FOR MAKING FLOORBOARDS

Technical Field

The invention generally relates to the field of mechanical locking of floorboards. The invention relates to an improved locking system for mechanical locking of floorboards, a floorboard provided with such an improved locking system, as well as a method for making such floorboards. The invention generally relates to an improvement to a locking system of the type described and shown in WO 9426999.

More specifically, the invention relates to a locking system for mechanical joining of floorboards of the type having a body, opposite first and second joint edge portions and a balancing layer on a rear side of the body, adjoining floorboards in a mechanically joined position having their first and second joint edge portions joined at a vertical joint plane, said locking system comprising

a) for vertical joining of the first joint edge portion of the first floorboard and the second joint edge portion of the adjoining floorboard mechanically cooperating means in the form of a tongue groove formed in the first joint edge portion and a tongue formed in the second joint edge portion,

b) for horizontal joining of the first joint edge portion of the first floorboard and the second joint edge portion of an adjoining floorboard mechanically cooperating means, which comprise

a locking groove which is formed in the underside of said second floorboard and which extends parallel to and at a distance from the vertical joint plane at said second joint edge portion and which has a downward opening, and

a strip made in one piece with the body of said first floorboard, which strip at said first joint edge portion projects from said vertical joint plane and at a distance from the joint plane has a locking element, which projects towards a plane containing the upper side of said first floorboard and which has at least one operative locking surface for coaction with said locking groove, and

5

10 said strip forming a horizontal extension of the first joint edge portion below the tongue groove.

Field of Application of the Invention

The present invention is particularly suitable for mechanical joining of thin floating floorboards made up of an upper surface layer, an intermediate fibreboard body and a lower balancing layer, such as laminate flooring and veneer flooring with a fibreboard body. Therefore, the following description of the state of the art, problems associated with known systems, and the objects and features of the invention will, as a non-restricting example, focus on this field of application and, in particular, on rectangular floorboards with dimensions of about 1.2 m * 0.2 m and a thickness of about 7-10 mm, intended to be mechanically joined at the long side as well as the short side.

15

20

25

Background of the Invention

Thin laminate flooring and wood veneer flooring are usually composed of a body consisting of a 6-9 mm fibreboard, a 0.2-0.8-mm-thick upper surface layer and a 0.1-0.6 mm lower balancing layer. The surface layer provides appearance and durability to the floorboards. The body provides stability, and the balancing layer keeps the board level when the relative humidity (RH) varies during the year. The RH can vary between 15% and 90%.

30

35 Conventional floorboards of this type are usually joined by means of glued tongue-and-groove joints at the long and short sides. When laying the floor, the

boards are brought together horizontally, whereby a projecting tongue along the joint edge of a first board is introduced into the tongue groove along the joint edge of a second board. The same method is used on both the long and the short side. The tongue and the tongue groove are designed for such horizontal joining only and with special regard to how the glue pockets and gluing surfaces should be designed to enable the tongue to be efficiently glued within the tongue groove. The tongue-and-groove joint presents coacting upper and lower contact surfaces that position the boards vertically in order to ensure a level surface of the finished floor.

In addition to such conventional floors which are connected by means of glued tongue-and-groove joints, floorboards have recently been developed which are instead mechanically joined and which do not require the use of glue. This type of a mechanical joint system is hereinafter referred to as a "strip-lock system" since the most characteristic component of this system is a projecting strip which supports a locking element.

WO 9426999 (Applicant Välinge Aluminium AB) discloses a strip-lock system for joining building panels, particularly floorboards. This locking system allows the boards to be locked mechanically at right angles to as well parallel to the principal plane of the boards at the long side as well as at the short side. Methods for making such floorboards are disclosed in WO 9824994 and WO 9824995. The basic principles of the design and the installation of the floorboards, as well as the methods for making the same, as described in the three above-mentioned documents are usable for the present invention as well, and, therefore, these documents are hereby incorporated by reference.

In order to facilitate the understanding and description of the present invention, as well as the comprehension of the problems underlying the invention, a brief description of the basic design and function of the

floorboards according to the above-mentioned WO 9426999 will be given below with reference to Figs 1-3 in the accompanying drawings. Where applicable, the following description of the prior art also applies to the embodi-
5 ments of the present invention described below.

Figs 3a and 3b are thus a bottom view and a top view respectively of a known floorboard 1. The board 1 is rectangular with a top side 2, an underside 3, two opposite long sides 4a, 4b forming joint edges, and two opposite
10 short sides 5a, 5b forming joint edges.

Without the use of glue, both the long sides 4a, 4b and the short sides 5a, 5b can be joined mechanically in a direction D2 in Fig. 1c. For this purpose, the board 1 has a flat strip 6, mounted at the factory, projecting
15 horizontally from its long side 4a, which strip extends throughout the length of the long side 4a and which is made of flexible, resilient sheet aluminium. The strip 6 can be fixed mechanically according to the embodiment shown, or by means of glue, or in some other way. Other
20 strip materials can be used, such as sheets of other metals, as well as aluminium or plastic sections. Alternatively, the strip 6 may be made in one piece with the board 1, for example by suitable working of the body of the board 1. Thus, the present invention is usable for
25 floorboards in which the strip is integrally formed with the board. At any rate, the strip 6 should always be integrated with the board 1, i.e. it should never be mounted on the board 1 in connection with the laying of the floor. The strip 6 can have a width of about 30 mm
30 and a thickness of about 0.5 mm. A similar, but shorter strip 6' is provided along one short side 5a of the board 1. The edge side of the strip 4 facing away from the joint edge 4a is formed with a locking element 8 extending throughout the length of the strip 6. The locking
35 element 8 has an operative locking surface 10 facing the joint edge 4a and having a height of e.g. 0.5 mm. When the floor is being laid, this locking surface 10 coacts

with a locking groove 14 formed in the underside 3 of the opposite long side 4b of an adjoining board 1'. The short side strip 6' is provided with a corresponding locking element 8', and the opposite short side 5b has a corresponding locking groove 14'.

Moreover, for mechanical joining of both the long sides and the short sides also in the vertical direction (direction D1 in Fig. 1c), the board 1 is formed with a laterally open recess 16 along one long side 4a and one short side 5a. At the bottom, the recess is defined by the respective strips 6, 6'. At the opposite edges 4b and 5b, there is an upper recess 18 defining a locking tongue 20 cooperating with the recess 16 (see Fig. 2a).

Figs 1a-1c show how two long sides 4a, 4b of two such boards 1, 1' on an underlay U can be joined together by means of downward angling. Figs 2a-2c show how the short sides 5a, 5b of the boards 1, 1' can be joined together by snap action. The long sides 4a, 4b can be joined together by means of both methods, while the short sides 5a, 5b - when the first row has been laid - are normally joined together subsequent to joining together the long sides 4a, 4b and by means of snap action only.

When a new board 1' and a previously installed board 1 are to be joined together along their long sides 4a, 4b as shown in Figs 1a-1c, the long side 4b of the new board 1' is pressed against the long side 4a of the previous board 1 as shown in Fig. 1a, so that the locking tongue 20 is introduced into the recess 16. The board 1' is then angled downwards towards the subfloor 12 as shown in Fig. 1b. In this connection, the locking tongue 20 enters the recess 16 completely, while the locking element 8 of the strip 6 enters the locking groove 14. During this downward angling the upper part 9 of the locking member 8 can be operative and provide guiding of the new board 1' towards the previously installed board 1. In the joined position as shown in Fig. 1c, the boards 1, 1' are locked in both the direction D1 and the direction D2 along their

long sides 4a, 4b, but can be mutually displaced in the longitudinal direction of the joint along the long sides 4a, 4b.

5 Figs 2a-2c show how the short sides 5a and 5b of the boards 1, 1' can be mechanically joined in the direction D1 as well as the direction D2 by moving the new board 1' towards the previously installed board 1 essentially horizontally. Specifically, this can be carried out subsequent to joining the long side of the new board 1' to
10 a previously installed board in an adjoining row by means of the method according to Figs 1a-1c. In the first step in Fig. 2a, bevelled surfaces adjacent to the recess 16 and the locking tongue 20 respectively co-operate such that the strip 6' is forced to move downwards as a direct
15 result of the bringing together of the short sides 5a, 5b. During the final urging together of the short sides, the strip 6' snaps up when the locking element 8' enters the locking groove 14'.

By repeating the steps shown in Figs 1a-c and 2a-c,
20 the whole floor can be laid without the use of glue and along all joint edges. Known floorboards of the above-mentioned type are thus mechanically joined usually by first angling them downwards on the long side, and when the long side has been secured, snapping the short sides
25 together by means of horizontal displacement along the long side. The boards 1, 1' can be taken up in the reverse order of laying without causing any damage to the joint, and be laid again. These laying principles are also applicable to the present invention.

30 For optimal function, subsequent to being joined together, the boards should be capable of assuming a position along their long sides in which a small play can exist between the locking surface 10 and the locking groove 14. Reference is made to WO 9426999 for a
35 more detailed description of this play.

In addition to what is known from the above-mentioned patent specifications, a licensee of Välinge Aluminium

AB, Norske Skog Flooring AS (NSF), introduced a laminated floor with mechanical joining according to WO 9426999 in January 1996 in connection with the Domotex trade fair in Hannover, Germany. This laminated floor, which is marketed under the brand name Alloc[®], is 7.2 mm thick and has a 0.6-mm aluminium strip which is mechanically attached on the tongue side. The operative locking surface of the locking element has an inclination (hereinafter termed locking angle) of 80° to the plane of the board. The vertical connection is designed as a modified tongue-and-groove joint, the term "modified" referring to the possibility of bringing the tongue and tongue groove together by way of angling.

WO 9747834 (Applicant Unilin) describes a strip-lock system which has a fibreboard strip and is essentially based on the above known principles. In the corresponding product, "Uniclic", which this applicant began marketing in the latter part of 1997, one seeks to achieve biasing of the boards. This results in high friction and makes it difficult to angle the boards together and to displace them. The document shows several embodiments of the locking system. The "Uniclic" product, shown in section in Fig. 4b, consists of a floorboard having a thickness of 8.1 mm with a strip having a width of 5.8 mm, comprising an upper part made of fibreboard and a lower part composed of the balancing layer of the floorboard. The strip has a locking element 0.7 mm in height with a locking angle of 45°. The vertical connection consists of a tongue and a tongue groove having a tongue groove depth of 4.2 mm.

Other known locking systems for mechanical joining of board materials are described in, for example, GB-A-2,256,023 showing unilateral mechanical joining for providing an expansion joint in a wood panel for outdoor use, and in US-A-4,426,820 showing a mechanical locking system for plastic sports floors, which floor however does not permit displacement and locking of the short

sides by snap action. In both these known locking systems the boards are uniform and do not have a separate surface layer and balancing layer.

5 In the autumn of 1998, NSF introduced a 7.2-mm laminated floor with a strip-lock system which comprises a fibreboard strip and is manufactured in accordance with WO 9426999. This laminated floor, which is shown in cross-section in Fig. 4a, is marketed under the brand name of "Fiboloc[®]". In this case, too, the strip comprises an upper part of fibreboard and a lower part
10 composed of a balancing layer. The strip is 10.0 mm wide, the height of the locking element is 1.3 mm and the locking angle is 60°. The depth of the tongue groove is 3.0 mm.

15 In January 1999, Kronotex introduced a 7.8 mm thick laminated floor with a strip lock under the brand name "Isilock". This system is shown in cross-section in Fig. 4c. In this floor, too, the strip is composed of fibreboard and a balancing layer. The strip is 4.0 mm
20 and the tongue groove depth is 3.6 mm. "Isilock" has two locking ridges having a height of 0.3 mm and with locking angles of 40°. The locking system has low tensile strength, and the floor is difficult to install.

Summary of the Invention

25 Although the floor according to WO 9426999 and the floor sold under the brand name Fiboloc[®] exhibit major advantages in comparison with traditional, glued floors, further improvements are desirable mainly by way of cost savings which can be achieved by reducing the width of
30 the fibreboard strip from the present 10 mm. A narrower strip has the advantage of producing less material waste in connection with the forming of the strip. However, this has not been possible since narrower strips of the Uniclic and Isilock type have produced inferior test
35 results. The reason for this is that narrow strips require a small angle of the locking surface of the locking element in relation to the horizontal plane (termed

locking angle) in order to enable the boards to be joined together by means of angling, since the locking groove follows an arc having its centre in the upper joint edge of the board. The height of the locking element must also
5 be reduced since narrow strips are not as flexible, rendering snap action more difficult.

To sum up, narrow strips have the advantage that material waste is reduced, but the drawbacks that the locking angle must be small to permit angling and that
10 the locking element must be low to permit joining by snap action.

In repeated laying trials and tests with the same batch of floorboards we have discovered that strip locks, which have a joint geometry similar to that in Figs 4b
15 and 4c, and are composed of a narrow fibreboard strip with a balancing layer on its rear side and with a locking element having a small locking surface with a low locking angle, exhibit a considerable number of properties which are not constant and which can vary substantially in the same floorboard at different points in time
20 when laying trials have been performed. These problems and the reason behind the problems are not known.

Moreover, at present there are no known products or methods which afford adequate solutions to these problems
25 which are related to

- (i) mechanical strength of the joint of floorboards with a mechanical locking system of the strip lock type;
- (ii) handling and laying of such floorboards;
- 30 (iii) properties of a finished, joined floor made of such floorboards.

(i) Strength

At a certain point in time, the joint system of the floorboards has adequate strength. In repeated testing
35 at a different point in time, the strength of the same floorboard may be considerably lower, and the locking element slides out of the locking groove relatively

easily when the floor is subjected to tensile stress transversely of the joint.

(ii) Handling/Laying

At certain times during the year the boards can be joined together, while at other times it is very difficult to join the same floorboard. There is a considerable risk of damage to the joint system in the form of cracking.

(iii) Properties of the Joined Floor

The quality of the joint in the form of the gap between the upper joint edges of the floorboards when subjected to stress varies for the same floorboard at different times during the year.

It is known that floorboards expand and shrink during the year when the relative humidity RH changes. Expansion and shrinking are 10 times greater transversely of the direction of the fibres than in the direction of the fibres. Since both joint edges of the joint system change by the same amount essentially simultaneously, the expansion and the shrinking cannot explain the undesirable effects which severely limit the chances of providing a strip-lock system at a low cost which at the same time is of high quality with respect to strength, laying properties, and the quality of the joint. According to generally known theories, wide strips should expand more and cause greater problems. Our tests indicate that the reverse is the case.

In sum, there is a great need for a strip-lock system which to a greater extent than the prior art takes into account the above-mentioned requirements, problems and wishes. It is an object of the invention to fulfil this need.

These and other objects of the invention are achieved by a locking system, a floorboard, and a manufacturing method exhibiting the properties stated in the appended independent claims, preferred embodiments being stated in the dependent claims.

The invention is based on a first insight according to which the problems identified are essentially connected to the fact that the strip which is integrated with the body bends upwards and downwards when the RH changes. Moreover, the invention is based on the insight that, as a result of its design, the strip is unbalanced and acts as a bimetal. When, in a decrease of the RH, the rear balancing layer of the strip shrinks more than the fibre-board part of the strip, the entire strip will bend backwards, i.e. downwards. Such strip-bending can be as great as about 0.2 mm. A locking element having a small operative locking surface, e.g. 0.5 mm, and a low locking angle, e.g. 45 degrees, will then cause a play in the upper part of the horizontal locking system, which means that the locking element of the strip easily slides out of the locking groove. If the strip is straight or slopes upward it will be extremely difficult to lay the floor if the locking system is adapted to a curved strip.

One reason why the problem is difficult to solve is that the deflection of the strip is not known when the floor is being laid or when it has been taken up and is being laid again, which is one of the major advantages of the strip lock in comparison with glued joints. Consequently, it is not possible to solve the problem by adapting in advance the working measurements of the strip and/or the locking groove to the curvature of the strip, since the latter is unknown.

Nor is it preferred to solve this problem by using a wide strip, whose locking element has a higher locking surface with a larger locking angle, since a wide strip has the drawback of considerable material wastage in connection with the forming of the strip. The reason why the wider but more costly strip works better is mainly because the locking surface is substantially larger than the maximum strip bending and because the high locking angle only causes a marginally greater play which is not visible.

The strip-bending problems are reinforced by the fact that laminate flooring is subjected to unilateral moisture influence. The surface layer and the balancing layer do not co-operate fully, and this always gives rise to a certain amount of bulging. Concave upward bulging is the biggest problem, since this causes the joint edges to rise. The result is an undesirable joint opening between the boards in the upper side of the boards and high wear of the joint edges. Accordingly, it is desirable to provide a floorboard which in normal relative humidity is somewhat upwardly convex by biasing the rear balancing layer. In traditional, glued floors this biasing is not a problem, rather, it creates a desirable advantage. However, in a mechanically joined floor with an integrated strip lock the biasing of the balancing layer results in an undesirable drawback since the bias reinforces the imbalance of the strip and, consequently, causes a greater, undesirable backward bending of the strip. This problem is difficult to solve since the bias is an inherent quality of the balancing layer, and, consequently, cannot be eliminated from the balancing layer.

The invention is also based on a second insight which is related to the geometry of the joint. We have also discovered that a strip lock with a relatively deep tongue groove gives rise to greater undesirable bending of the strip. The reason behind this phenomenon is that the tongue groove, too, is unbalanced. Consequently, the tongue groove opens when, in a decrease of the RH, the balancing layer shrinks to a greater extent than the fibreboard part of the strip, causing the strip to bend downwards since the strip is an extension of the joint edge below the tongue groove.

According to a first aspect of the invention a locking system is provided of the type which is stated in the first paragraph but one of the description and which, according to the invention, is characterised in that the second joint edge, within an area (P) defined by the bot-

tom of the tongue groove and the locking surface of the locking element, is modified with respect to the balancing layer.

Said area P, which is thus defined by the bottom
5 of the tongue groove and the locking surface of the locking element, is the area which is sensitive to bending. If the strip bends within this area P, the position of the locking surface relative to the locking groove, and thus the properties of the joint, will be affected. Especially, it should be noted that this entire area P is
10 unbalanced, since nowhere does the part of the balancing layer located in this area P have a coating, balancing surface layer, neither in the tongue groove nor on the projecting strip. According to the invention, by modifying
15 the balancing layer within this area P it is possible to change this unbalanced state in a positive direction, such that the undesirable strip-bending is reduced or eliminated.

The term "modified" refers to both (i) a preferred
20 embodiment in which the balancing layer has been modified "over time", i.e. the balancing layer has first been applied across the entire area P during the manufacturing process, but has then been subjected to modifying treatment, such as milling or grooving and/or chemical working,
25 and (ii) variants in which the balancing layer at least across part of the area P has been modified "in space", i.e. that the area P differs from the rest of the board with respect to the appearance/properties/structure
of the balancing layer.

30 The balancing layer can be modified across the entire horizontal extent of the area P, or within only one or several parts thereof. The balancing layer can also be modified under the whole of the locking element or parts thereof. However, it may be preferable to keep
35 the balancing layer intact under at least part of the locking element to provide support for the strip against the underlay.

According to a preferred embodiment, "modifying" means that the balancing layer is completely or partially removed. In one embodiment, the whole area P lacks a balancing layer.

5 In a second embodiment, there is no balancing layer, at all within one or several parts of the area P. Depending on the type of balancing layer and the geometry of the joint system, it is, for example, possible to keep the whole balancing layer or parts thereof under the
10 tongue groove.

In a third embodiment, the balancing layer is not removed completely; it is only reduced in thickness. The latter embodiment can be combined with the former ones. There are balancing layers where the main problems can
15 be eliminated by partial removal of some layers only. The rest of the balancing layer can be retained and helps to increase the strength and flexibility of the strip. Balancing layers can also be specially designed with different layers which are adapted in such a way that they
20 both balance the surface and can act as a support for the strip when parts of the layers are removed within one area of the rear side of the strip.

The modification can also mean a change in the material composition and/or material properties of the balancing layer.
25

Preferably, the modification can be achieved by means of machining such as milling and/or grinding but it could also be achieved by means of chemical working, heat treatment or other methods which remove material or
30 change material properties.

The invention also provides a manufacturing method for making a moisture-stable strip-lock system. The method according to the invention comprises the steps of forming each floorboard from a body,
35 providing the rear side of the body with a balancing layer,

forming the floorboard with first and second joint edge portions,

forming said first joint edge portion with

5 a first joint edge surface portion extended from the upper side of the floorboard and defining a joint plane along said first joint edge portion,

a tongue groove which extends into the body from said joint plane,

10 a strip formed from the body and projecting from said joint plane and supporting at a distance from this joint plane an upwardly projecting locking element with a locking surface facing said joint plane,

forming said second joint edge portion with

15 a second joint edge surface portion extended from the upper side of the floorboard and defining a joint plane along said second joint edge portion,

a tongue projecting from said joint plane for cooperation with a tongue groove of the first joint edge portion of an adjoining floorboard, and

20 a locking groove which extends parallel to and at a distance from the joint plane of said second joint edge portion and which has a downward opening and is designed to receive the locking element and cooperate with said locking surface of the
25 locking element.

The method according to the invention is characterised by the step of working the balancing layer within an area defined by the bottom of the tongue groove and the
30 locking surface of the locking element.

The adaptation or removal of part of the balancing layer in the joint system can be carried out in connection with the gluing/lamination of the surface layer, the body, and the balancing layer by displacing the balancing
35 layer relative to the surface layer. It is also possible to carry out modifications in connection with the manufacture of the balancing layer so that the part which

will be located adjacent to the locking system will have properties which are different from those of the rest of the balancing layer.

5 However, a very suitable manufacturing method is machining by means of milling or grinding. This can be carried out in connection with the manufacture of the joint system and the floorboards can be glued/laminated in large batches consisting of 12 or more floorboards.

10 The strip-lock system is preferably manufactured using the upper floor surface as a reference point. The thickness tolerances of the floorboards result in strips of unequal thickness since there is always a predetermined measurement from the top side of the strip to the floor. Such a manufacturing method results in tongue
15 grooves of different depths in the rear side and a partial removal of a thin balancing layer cannot be performed in a controlled manner. The removal of the balancing layer should thus be carried out using the rear side of the floorboard as a reference surface instead.

20 It has also been an object to provide a cost-optimal joint which is also of high-quality by making the strip as narrow as possible and the tongue groove as shallow and as strong as possible in order both to reduce waste since the tongue can be made narrow and to eliminate as
25 far as possible the situation where the tongue groove opens up and causes strip-bending as well as rising of the upper joint edge when the relative humidity changes.

Known strip-lock systems with a strip of fibreboard and a balancing layer are characterised in that the shallowest known tongue groove is 3.0 mm in a 7.2-mm-thick
30 floorboard. The depth of the tongue groove is thus 0.42 times the thickness of the floor. This is only known in combination with a 10.0-mm-wide strip which thus has a width which is 1.39 times the floor thickness. All other
35 such known strip joints with narrow strips have a tongue groove depth exceeding 3.6 mm and this contributes considerably to the strip-bending.

In order to fulfil the above-mentioned object a strip-lock system is provided which is characterised in that the tongue groove depth of the tongue groove and the width of the strip are less than 0.4 and 1.3 times the floor thickness respectively. This joint affords good joint properties and especially in combination with high rigidity of the tongue groove since it can be designed in such a way that as much material as possible is retained between the upper part of the tongue groove and the floor surface as well as between the lower part of tongue groove and the rear side of the floor while, at the same time, it is possible to eliminate the strip-bending problems as described above. This strip-lock system can be combined with one or more of the preferred embodiments which are disclosed in connection with the solution based on a modification of the balancing layer.

The opposite joint edge of the board is also unbalanced. In this case, the problems are not nearly as serious since the surface layer is not biased and the unbalanced part is more rigid. However, in this case, too, an improvement can be achieved by making the strip as thin as possible. This permits minimal removal of material in the locking groove part of the joint system, which in turn results in maximum rigidity in this unbalanced part.

According to the invention there is thus provided a strip-lock system having a joint geometry characterised in that there is a predetermined relationship between the width and thickness of the strip and the height of the locking element on the one hand and the floor thickness on the other. Furthermore, there is provided a minimum locking angle for the locking surface. All these parameters separately and in combination with each other and the above inventions contribute to the creation of a strip-lock system which can have high joint quality and which can be manufactured at a low cost.

Brief Description of the Drawings

Figs 1a-c show in three stages a downward angling method for mechanical joining of long sides of floorboards according to WO 9426999.

5 Figs 2a-c show in three stages a snap-action method for mechanical joining of short sides of floorboards according to WO 9426999.

Figs 3a and 3b are a top view and a bottom view respectively of a floorboard according to WO 9426999.

10 Fig. 4 shows three strip-lock systems available on the market with an integrated strip of fibreboard and a balancing layer.

Fig. 5 shows a strip lock with a small tongue groove depth and with a wide fibreboard strip, which supports a locking element having a large locking surface and a high locking angle.

15 Fig. 6 shows a strip lock with a large tongue groove depth and with a narrow fibreboard strip, which supports a locking element having a small locking surface and a low locking angle.

Figs 7 and 8 illustrate strip-bending in a strip lock according to Fig. 5 and Fig. 6.

Fig. 9 shows the joint edges of a floorboard according to an embodiment of the invention.

25 Figs 10 and 11 show the joining of two floorboards according to Fig. 9.

Figs 12 and 13 show two alternative embodiments of the invention.

Description of Preferred Embodiments

30 Prior to the description of preferred embodiments, with reference to Figs 5-8, a detailed explanation will first be given of the background to and the impact of strip-bending.

35 The cross-sections shown in Figs 5 and 6 are hypothetical, unpublished cross-sections, but they are fairly similar to "Fiboloc[®]" in Fig. 4a and "Uniclic" in Fig. 4b. Accordingly, Figs 5 and 6 do not represent the

invention. Parts which correspond to those in the previous Figures are in most cases provided with the same reference numerals. The design, function, and material composition of the basic components of the boards in
5 Figs 5 and 6 are essentially the same as in embodiments of the present invention and, consequently, where applicable, the following description of Figs 5 and 6 also applies to the subsequently described embodiments of the invention.

10 In the embodiment shown, the floorboards 1, 1' in Fig. 5 are rectangular with opposite long sides 4a, 4b and opposite short sides 5a, 5b. Fig. 5 shows a vertical cross-section of a part of a long side 4a of the board 1, as well as a part of a long side 4b of an adjoining board
15 1'. The body of the board 1 can be composed of a fibre-board body 30, which supports a surface layer 32 on its front side and a balancing layer 34 on its rear side. A strip 6 formed from the body and the balancing layer of the floorboard and supporting a locking element 8 consti-
20 tutes an extension of the lower tongue groove part 36 of the floorboard 1. The strip 6 is formed with a locking element 8, whose operative locking surface 10 cooperates with a locking groove 14 in the opposite joint edge 4b of the adjoining board 1' for horizontal locking of the
25 boards 1, 1' transversely of the joint edge (D2). The locking element 8 has a relatively large height LH and a high locking angle A. The upper part of the locking element has a guiding part 9 which guides the floorboard to the correct position in connection with angling. The
30 locking groove 14 has a larger width than the locking element 8, as is evident from the Figures.

For the purpose of forming a vertical lock in the direction D1, the joint edge portion 4a exhibits a laterally open tongue groove 36 and the opposite joint edge
35 portion 4b exhibits a tongue 38 which projects laterally from a joint plane F and which in the joined position is received in the tongue groove 36.

In the joined position according to Fig. 5, the two adjoining, upper joint edge surface portions 41 and 42 of the boards 1, 1' define this vertical joint plane F.

The strip 6 has a horizontal extent W (= strip width) which can be divided into: (a) an inner part with a horizontal extent D (locking distance) which is defined by the joint plane F and a vertical line through the lower part of the locking surface 10, as well as (b) an outer part with a horizontal extent L (the width of the locking element). The tongue groove 36 has a horizontal tongue groove depth G measured from the joint plane F and inwards towards the board 1 to a vertical limiting plane which coincides with the bottom of the tongue groove 36. The tongue groove depth G and the extent D of the locking distance together form a joint part within an area P consisting of components forming part of the vertical lock D1 and the horizontal lock D2.

Fig. 6 shows an embodiment which is different from the embodiment in Fig. 5 in that the tongue groove depth G is greater, and the strip width W , the height LH , and the locking angle A of the locking surface are all smaller. However, the size of the area P is the same in the embodiments in Figs 5 and 6.

Reference is now made to Figs 7 and 8, which show strip-bending in the embodiments in Figs 5 and 6 respectively. The relevant part of the curvature which may cause problems is the area P, since a curvature in the area P results in a change of position of the locking surface 10. Since the area P has the same horizontal extent in both embodiments, all else being equal, the strip-bending at the locking surface 10 will be of the same magnitude despite the fact that the strip length W is different.

The large locking surface 10 and the large locking angle A in Fig. 5 will not cause any major problems in Fig. 7, since the greater part of the locking surface 10 is still operative. The high locking angle A contributes

only marginally to increased play between the locking element 8 and the locking groove 14. In Fig. 8, however, the large tongue groove depth G as well as the small locking surface 10 and the low locking angle A2 create major problems. The strength of the locking system is considerably reduced and the play between the locking element 8 and the locking groove 14 increases substantially and causes joint openings in connection with tensile stress. If the play of the boards is adapted to a sloping strip at the time of manufacture it may prove impossible to lay the boards if the strip 6 is flat or bent upwards.

We have realised that the strip-bending is a result of the fact that the joint part P is unbalanced and that the shape changes in the balancing layer 34 and the fibreboard part 30 of the strip are not the same when the relative humidity changes. In addition, the bias of the balancing layer 34 contributes to bending the strip 6 backwards/downwards.

The deciding factors of the strip-bending are the extent of the locking distance D and the tongue groove depth G. The appearance of the tongue groove 36 and the strip 6 also has some importance. A great deal of material in the joint portion P makes the tongue groove and the strip more rigid and counteracts strip-bending.

Figs 9-11 show how a cost-efficient strip-lock system with a high quality joint can be designed according to the invention. Fig. 9 shows a vertical cross-section of the whole board 1 seen from the short side, with the main portion of the board broken away. Fig. 10 shows two such boards 1, 1' joined at the long sides 4a, 4b. Fig. 11 shows how the long sides can be angled together in connection with laying and angled upward when being taken up. The short sides can be of the same shape.

In connection with the manufacture of the strip-lock system, the balancing layer 34 has been milled off both in the entire area G under the tongue groove 36 and

across the entire rear side of the strip 6 across the width W (including the area L under the locking element 8). The modification according to the invention in the form of removal of the balancing layer 34 in the whole area P eliminates both the bias and the strip-bending resulting from moisture movement.

In order to save on materials, in this embodiment the width W of the strip 6 has been reduced as much as possible to a value which is less than 1.3 times the floor thickness.

The tongue groove depth G of the tongue groove 36 has also been limited as much as possible both to counteract undesirable strip-bending and to save on materials. In its lower part, the tongue groove 36 has been given an oblique part 45 in order to make the tongue groove 36 and the joint portion P more rigid.

In order to counteract the effect of the strip-bending and to comply with the strength requirements, the locking surface has a minimum inclination of at least 45 degrees and the height of the locking element exceeds 0.1 times the floor thickness T.

In order to make the locking-groove part of the joint system as stable as possible, the thickness SH of the strip in an area corresponding to at least half the locking distance D has been limited to a maximum of 0.25 times the floor thickness T. The height LH of the locking element has been limited to 0.2 times the floor thickness and this means that the locking groove 14 can be formed by removing a relatively small amount of material.

In more basic embodiments of the invention, only the measure "modification of balancing layer" is used.

Fig. 12 shows an alternative embodiment for eliminating undesirable strip-bending. Here, the balancing layer 34 has been completely removed within the area P (including area G under the tongue groove). However, under the locking element 8 in the area L the balancing

layer is intact in the form of a remaining area 34', which advantageously constitutes a support for the locking element 8 against the subfloor. Since the remaining part 34' of the balancing layer is located outside the locking surface 10 it only has a marginal, if any, negative impact on the change of position of the locking surface 10 in connection with strip-bending and thus changes in moisture content.

Within the scope of the invention there are a number of alternative ways of reducing strip-bending. For example, several grooves of different depths and widths can be formed in the balancing layer within the entire area P and L. Such grooves could be completely or partially filled with materials which have properties that are different from those of the balancing layer 34 of the floorboard and which can contribute to changes in the properties of the strip 6 with respect to, for example, flexibility and tensile strength. Filling materials with fairly similar properties can also be used when the objective is to essentially eliminate the bias of the balancing layer.

Complete or partial removal of the balancing layer P in the area P and refilling with suitable bonding agents, plastic materials, or the like can be a way of improving the properties of the strip 6.

Fig. 13 shows an embodiment in which only part of the outer layer of the balancing layer has been removed across the entire area P. The remaining, thinner part of the balancing layer is designated 34". The part 34' has been left intact under the locking element 8 in the area L. The advantage of such an embodiment is that it may be possible to eliminate the major part of the strip-bending while a part (34") of the balancing layer is kept as a reinforcing layer for the strip 6. This embodiment is particularly suitable when the balancing layer 34 is composed of different layers with different properties. The outer layer can, for example, be made of melamine and

decoration paper while the inner layer can be made of phenol and Kraft paper. Various plastic materials can also be used with various types of fibre reinforcement. Partial removal of layers can, of course, be combined
5 with one or more grooves of different depths and widths under the entire joint system P + L. The working from the rear side can also be adapted in order to increase the flexibility of the strip in connection with angling and snap action.

10 Two main principles for reducing or eliminating strip-bending have now been described namely: (a) modifying the balancing layer within the entire area P or parts thereof, and (b) modifying the joint geometry itself with a reduced tongue groove depth and a special design of the
15 inner part of the tongue groove in combination. These two main principles are usable separately to reduce the strip-bending problem, but preferably in combination.

According to the invention, these two basic principles can also be combined with further modifications of
20 the joint geometry (c) which are characterised in that:

- The strip is made narrow preferably less than 1.3 times the floor thickness;
- The inclination of the locking surface is at least 45 degrees;
- 25 - The height of the locking element exceeds 0.1 times the floor thickness and is less than 0.2 times the floor thickness;
- The strip is designed so that at least half the locking distance has a thickness which is less than 0.25
30 times the floor thickness.

The above embodiments separately and in combination with each other and the above main principles contribute to the provision of a strip-lock system which can be manufactured at a low cost and which at the same affords
35 a high quality joint with respect to laying properties, disassembly options, strength, joint opening, and stability over time and in different environments.

Several variants of the invention are possible. The joint system can be made in a number of different joint geometry where some or all of the above parameters are different, particularly when the purpose is to give precedence to a certain property over the others.

Applicant has considered and tested a large number of variants in the light of the above: "smaller" can be changed to "larger", relationships can be changed, other radii and angles can be chosen, the joint system on the long side and the short side can be made different, two types of boards can be made where, for example, one type has a strip on both opposite sides while the other type has a locking groove on the corresponding sides, boards can be made with strip locks on one side and a traditional glued joint on the other, the strip-lock system can be designed with parameters which are generally intended to facilitate laying by positioning the floorboards and keeping them together until the glue hardens, and different materials can be sprayed on the joint system to provide impregnation against moisture, reinforcement, or moisture-proofing, etc. In addition, there can be mechanical devices, changes in the joint geometry and/or chemical additives such as glue which are aimed at preventing or impeding, for example, a certain type of laying (angling or snap action), displacement in the direction of the joint, or a certain way of taking up the floor, for example, upward angling or pulling along the joint edge.

CLAIMS

1. A locking system for mechanical joining of floorboards (1) of the type having a body (30), opposite first and second joint edge portions (4a, 4b) and a balancing layer (34) on the rear side of the body (30), adjoining floorboards (1, 1') in a mechanically joined position having their first and second joint edge portions (4a, 4b) joined at a vertical joint plane (F), said locking system comprising:
- a) for vertical joining of the first joint edge portion (4a) of the first floorboard (1) and the second joint edge portion (4a, 4b) of the adjoining second floorboard (1') mechanically cooperating means (36, 38) in the form of a tongue groove (36) formed in the first joint edge portion (4a) and a tongue (38) formed in the second joint edge portion (4b),
 - b) for horizontal joining of the first joint edge (4a) of a first floorboard (1) and the second joint edge portion (4b) of an adjoining floorboard (1') mechanically cooperating means (6, 8; 14) comprising
 - a locking groove (14) formed in the underside (3) of said second board (1') and extending parallel to and at a distance from the vertical joint plane (F) at said second joint edge portion (4b) and having a downward opening, and
 - a strip (6) integrally formed with the body (30) of said first floor board (1), which strip at said first joint edge portion (4a) projects from said vertical joint plane (F) and at a distance from the joint plane (F) has a locking element (8), which projects towards a plane containing the upper side (2) of said first floorboard (1) and which has at least one operative locking surface (10) for coaction with said locking groove (14), and

the strip (6) forming a horizontal extension of the first joint edge portion (4a) below the tongue groove (36),

5 characterised in that the first joint edge portion (4a), within an area (P) defined by the bottom of the tongue groove (36) and the locking surface (10) of the locking element (8), is modified with respect to the balancing layer (34).

10 2. A locking system according to claim 1, wherein the balancing layer (34), within said area (P) of the first joint edge portion (4a), is lacking or is wholly or partially removed.

15 3. A locking system according to claim 1, characterised in that the balancing layer (34) within said area (P) of the first joint edge portion (4a) is modified with respect to its properties, compared with the properties of the balancing layer within the remaining parts of the floorboard (1).

20 4. A locking system according to any one of the preceding claims, wherein essentially the entire area (P) is modified with respect to the balancing layer.

25 5. A locking system according to any one of claims 1-2, wherein said area (P) is modified with respect to the balancing layer (34) across only a part of its horizontal extent.

6. A locking system according to claim 5, wherein said area (P) is modified with respect to the balancing layer (34) across more than half of its horizontal extent.

30 7. A locking system according to any one of the preceding claims, wherein the first joint edge portion (4a) is modified with respect to the balancing layer (34) also in a second area (L) under the locking element (8).

35 8. A locking system according to any one of claims 1-6, wherein the first joint edge portion (4a) exhibits a non-modified balancing layer (34') in a second area (L) under the locking element (8).

9. A locking system according to any one of the preceding claims, wherein said modification refers to an alteration of the thickness of the balancing layer (34).

10. A locking system according to any one of the preceding claims, wherein said area (P) has no balancing layer at all across at least part of its horizontal extent.

11. A locking system according to any one of the preceding claims, wherein said area, across its whole horizontal extent or a part thereof, exhibits a balancing layer (34) with reduced thickness.

12. A locking system according to any one of the preceding claims, wherein the first joint edge portion (4a) is modified within said area (P) with respect to the material composition of the balancing layer (34).

13. A locking system according to any one of the preceding claims, wherein the first joint edge portion (4a) within said area (P) is modified with respect to the material properties of the balancing layer (34).

14. A locking system according to any one of the preceding claims, wherein the locking system is designed in such a way that the tongue (38) is anglable into the tongue groove (36) and the locking element is insertable into the locking groove (14) by means of a mutual angular movement of the first and the second floorboard (1, 1') while maintaining contact between joint edge surface portions (41, 42) of the floorboards close to the boundary line between the joint plane (F) and the upper side (2) of the floorboards.

15. A locking system according to any one of the preceding claims, wherein the floorboards (1, 1') on the upper side (2) of the body (30) have a surface layer (32) which coacts with the balancing layer (34).

16. A locking system according to any one of the preceding claims, wherein the tongue groove (36) has a tongue groove depth (G) which is less than 0.4 times the thickness (T) of the board (1), and wherein the strip (6)

has a width (W) which is less than 1.3 times the thickness (T) of the board (1).

17. A locking system according to any one of the preceding claims, wherein the locking surface (10) of the locking element (8) has a vertical extent (LH) which is at least 0.1 times the thickness (T) of the board.

18. A locking system according to any one of the preceding claims, wherein the locking surface (10) of the locking element (8) is inclined relative to the horizontal plane at an angle (A) exceeding 45°.

19. A locking system according to any one of the preceding claims, wherein the tongue groove (36) exhibits an outer part (G2) with a vertical height and an inner, narrower part (G1) with a vertical height whose average value across the horizontal extent of the inner part (G1) is less than 0.8 times the vertical height of the outer part (G2).

20. A locking system according to any one of the preceding claims, wherein the locking surface (10) of the locking element (8) has a vertical extent (LH) which is less than 0.2 times the thickness (T) of the board.

21. A locking system according to any one of the preceding claims, wherein the strip (6), across at least half of the part (P) of the strip which in the horizontal direction is located between the locking surface (10) and the joint edge of the other board (1), exhibits a strip thickness (SH) which is less than 0.25 times the thickness (T) of the board.

22. A floorboard provided with a locking system according to any one of claims 1-21.

23. A floorboard according to claim 22, which is mechanically joinable to adjoining boards along all four sides by means of a strip-lock system.

24. A method for making mechanically joinable floorboards (1) comprising the steps of forming each floorboard (1) from a body (30),

providing the rear side of the body (30) with a balancing layer (34),

forming the floorboard with first and second joint edge portions (4a, 4b),

5 forming said first joint edge portion (4a) with a joint edge surface portion (41) extending from the upper side (2) of the floorboard and defining a joint plane (F) along said first joint edge portion (4a),

10 a tongue groove (36) which extends into the body from said joint plane (F),

a strip (6) formed from the body (30) and projecting from said joint plane (F) and supporting at a distance from this joint plane an upwardly projecting locking element (8) with a locking surface (10) which faces said joint plane (F),

forming said second joint edge portion (4b) with

20 a second joint edge surface portion (42) projecting from the upper side (2) of the floorboard and defining a joint plane (F) along said second joint edge portion (4b),

a tongue projecting from this joint plane for coaction with a tongue groove of the first joint edge portion (4a) of an adjoining floorboard, and

25 a locking groove (8) which extends parallel to and at a distance from the joint plane (F) of said second joint edge portion (4b) and which has a downward opening and is designed for receiving the locking element (8) and cooperating with said locking surface (10) of the locking element (8),

30 characterised by the step of working the balancing layer within an area (P) defined by the bottom of the tongue groove (36) and the locking surface (10) of the locking element (8).

35 25. A method according to claim 24, wherein the step of working the balancing layer (34) comprises machining.

26. A method according to claim 25, wherein the step of machining comprises groove-milling or slot-forming in said area (P).

27. A method according to claim 24, wherein the step
5 of working the balancing layer (34) comprises chemical working.

28. A method according to any one of claims 24-27, wherein the step of working the balancing layer (34) is carried out prior to the step of forming the strip (6)
10 from the body (30).

29. A method according to any one of claims 24-27, wherein the step of working the balancing layer (34) is carried out subsequent to the step of forming the strip (6) from the body (30).

30. A method according to any one of claims 24-29, wherein the step of working the balancing layer (34) is carried out using the rear side (3) of the board (1) as a reference surface such that the result of the working of the balancing layer (34) is independent of any thick-
15 20 ness tolerances of the floorboard (1).

31. A method according to any one of claims 24-30, wherein essentially the entire balancing layer is removed across the entire said area (P) as a result of said working.

32. A method according to any one of claims 24-30, wherein essentially the entire balancing layer is removed across only a part of said area (P) as a result of said working.

33. A method according to any one of claims 24-30, wherein the balancing layer (34) is only partially removed across at least a part (34") of said area (P) as a result of said working.

34. A method according to any one of claims 24-33, wherein the balancing layer (34) is worked across at
35 least 50% of said area.

35. A method according to any one of claims 24-33, wherein at least some of the spaces forming as a result

of the removal of the balancing layer (34) are filled at least partially with material which has properties different from those of the balancing layer (34).

36. A locking system for mechanical joining of
- 5 floorboards (1) which have a thickness (T) and exhibit a body (30), opposite first and second joint edge portions (4a, 4b), a balancing layer on the rear side of the body (30), adjoining floorboards (1, 1') in a mechanically
- 10 joined position having their first and second joint edge portions (4a 4b) joined at a vertical joint plane (F), and a balancing layer (34) on the rear side of the body (30), said system comprising
- a) for vertical joining of the first joint edge portion (4a) of the first floorboard (1) and the second joint
- 15 portion (4a, 4b) of the adjoining second floorboard (1') mechanically cooperating means (36, 38) in the form of a tongue groove (36) formed in the first joint edge portion (4a) and a tongue (38) formed in the second joint edge portion (4b), and
- 20 b) for horizontal joining of the first joint edge portion (4a) of a first floorboard (1) and the second joint edge portion (4a, 4b) of an adjoining second floorboard (1') mechanically cooperating means (6, 8; 14), which comprise
- 25 a locking groove (14) formed in the underside (3) of said second board (1') and extending parallel to and at a distance from the vertical joint plane (F) at said second joint edge portion (4) and having a downward opening, and
- 30 a strip (6) integrally formed with the body (30) of said first floorboard (1), said strip projecting at said first joint edge portion (4a) from said vertical joint plane (F) and at a distance from the joint plane (F) having a locking element (8), which
- 35 projects towards a plane containing the upper side (2) of said first floorboard (1) and which has at

least one operative locking surface (10) for coaction with said locking groove (14), and the strip (6) forming a horizontal extension of the first joint edge portion (4a) below the tongue groove (36),

5

characterised in that the tongue groove depth (G) is less than 0.4 times the thickness (T) of the board (1), and that the strip width (W) is less than 1.3 times the thickness (T) of the board (1).

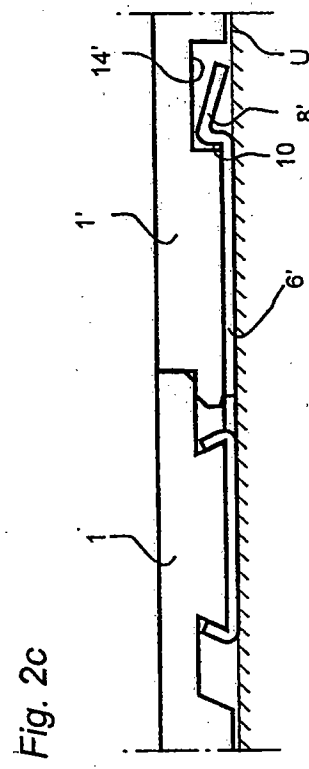
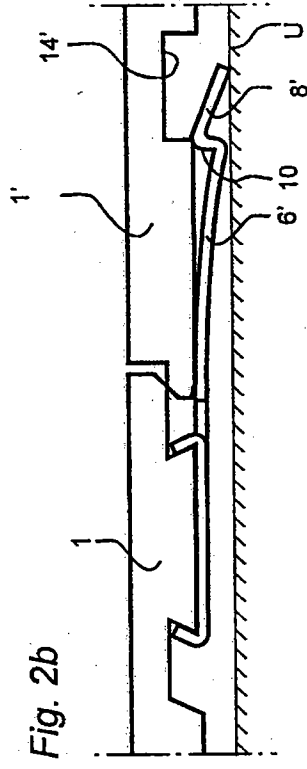
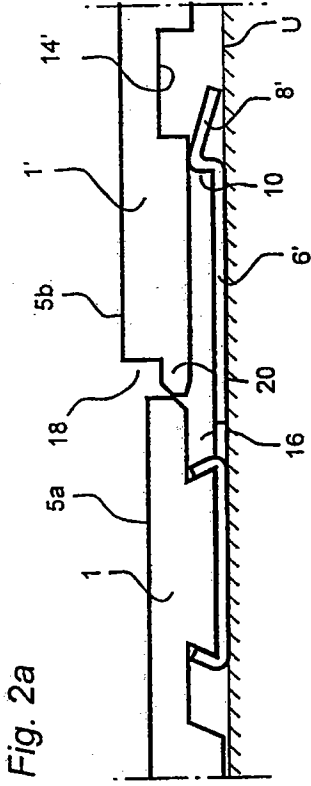

PRIOR ART

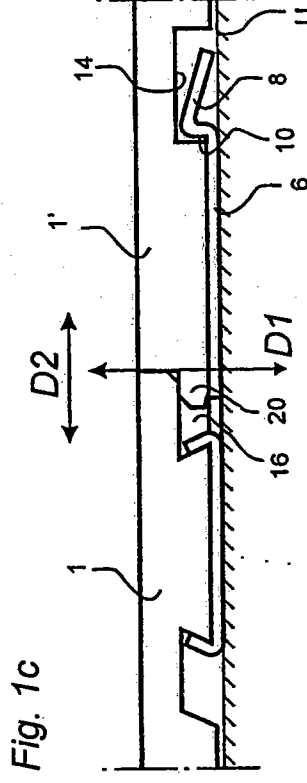
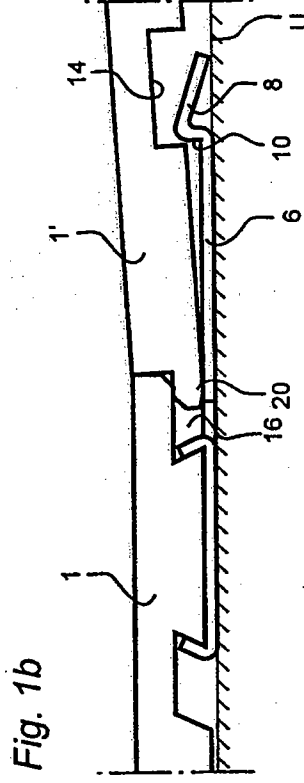
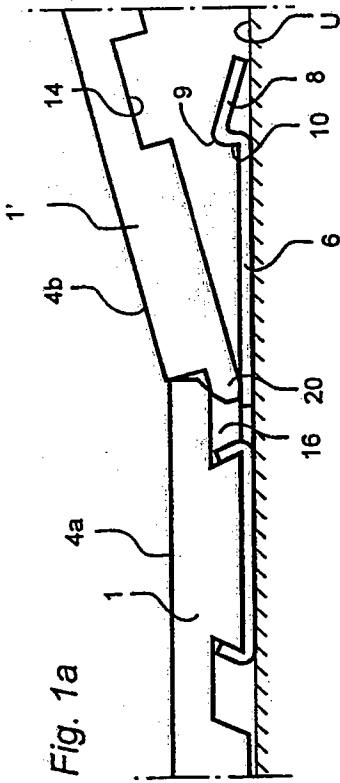

PRIOR ART

Fig. 3a

Fig. 3b

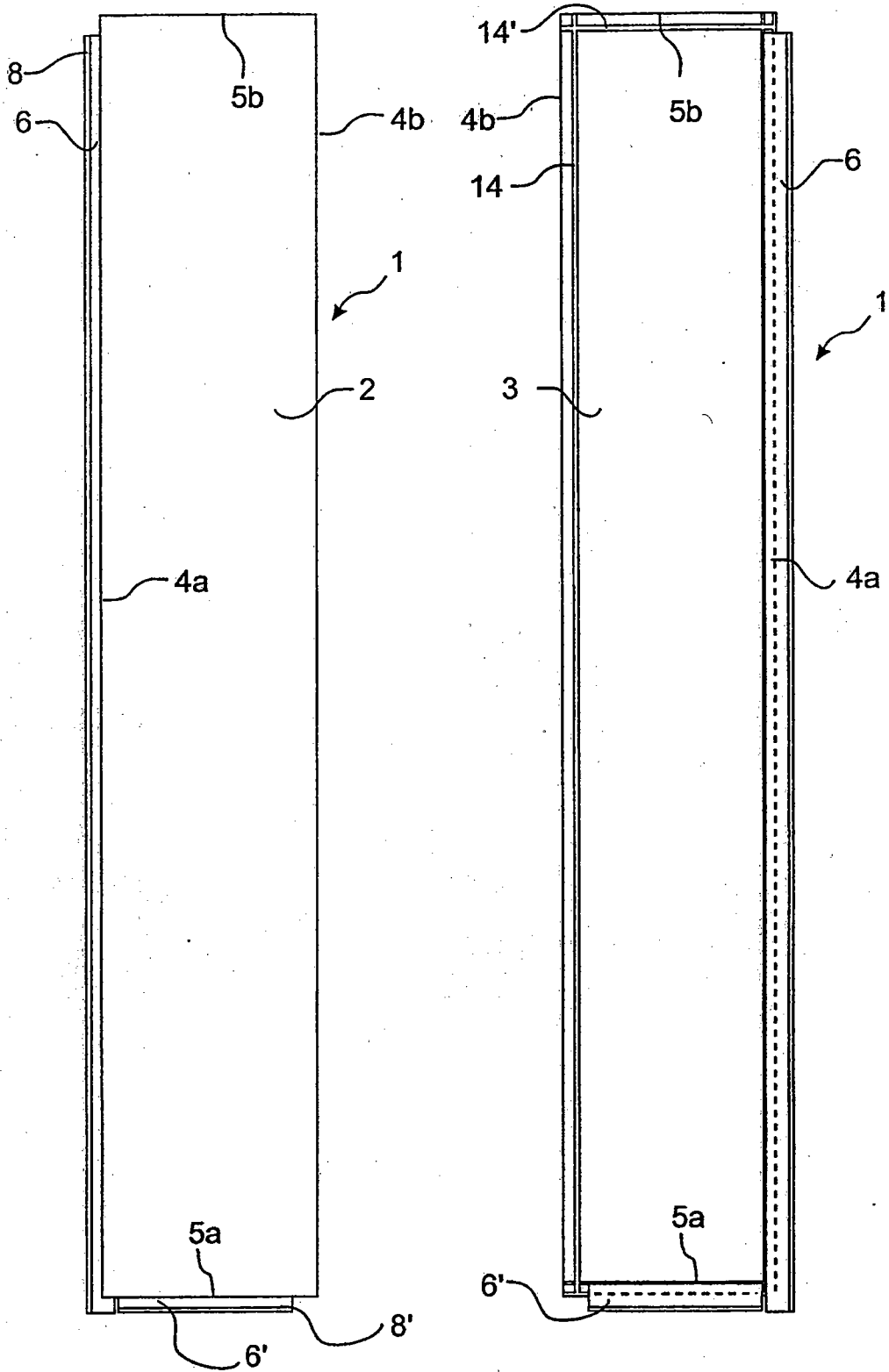

PRIOR ART

Fig. 4a

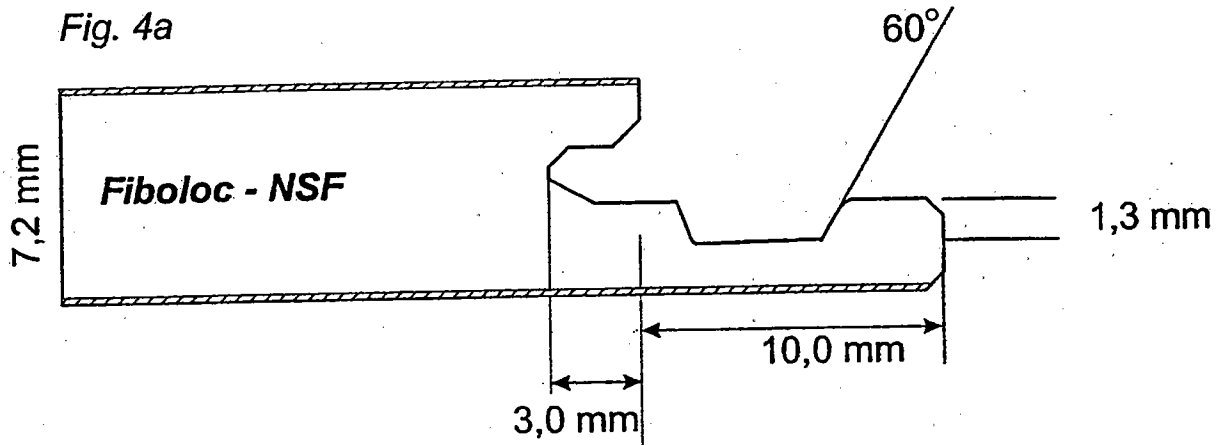

Fig. 4b

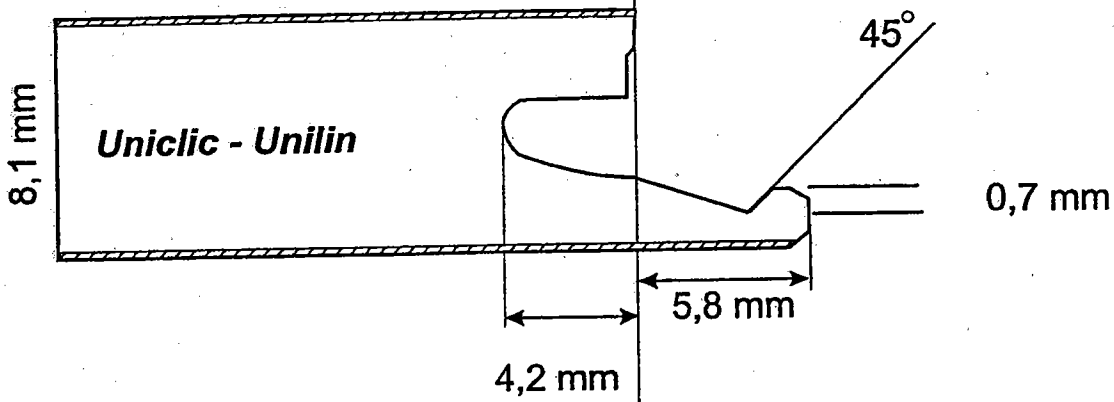
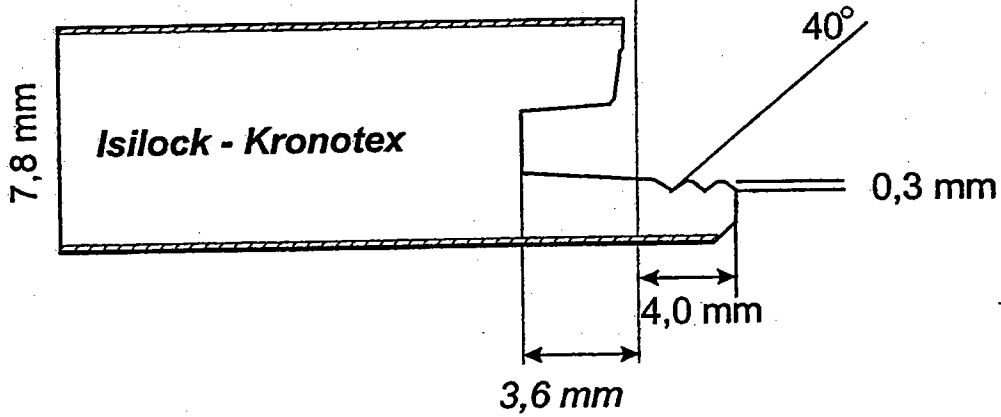
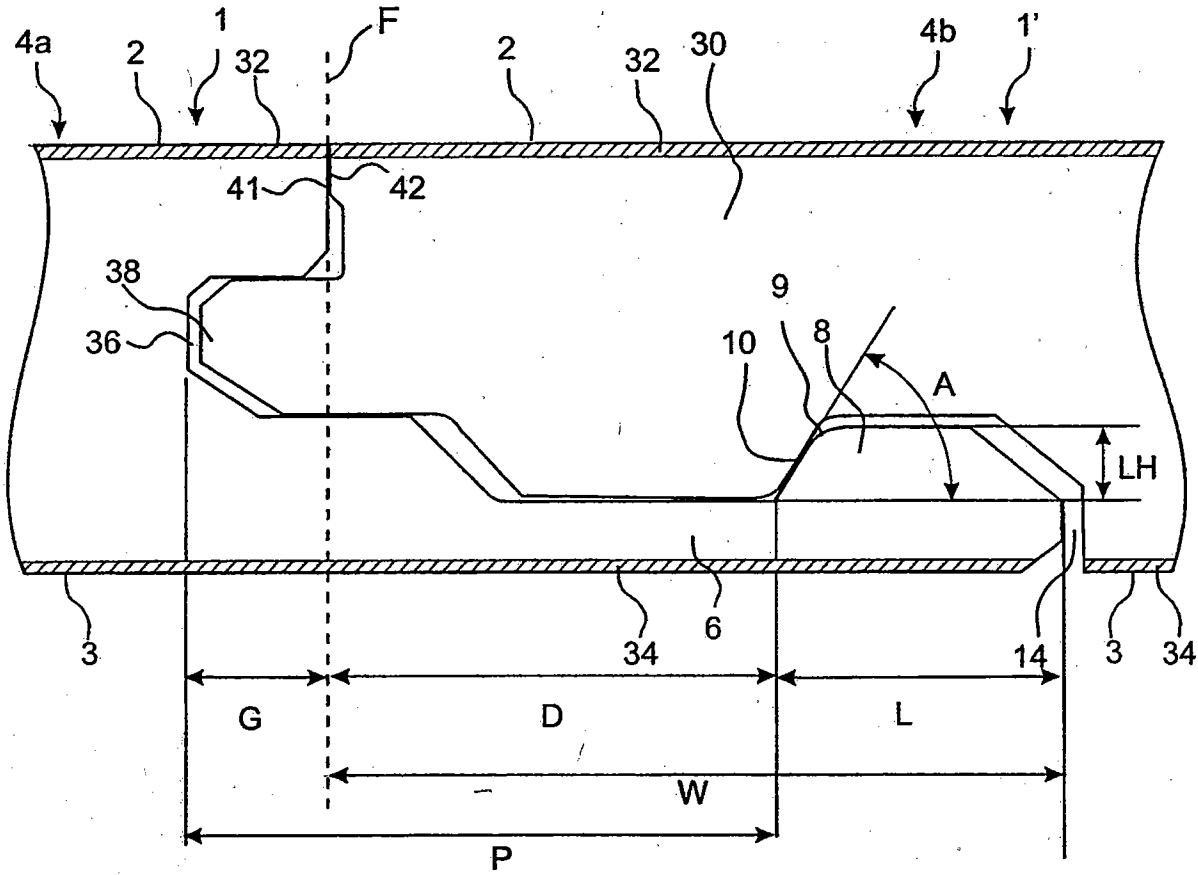

Fig. 4c



PRIOR ART

Fig. 5



PRIOR ART

Fig. 6

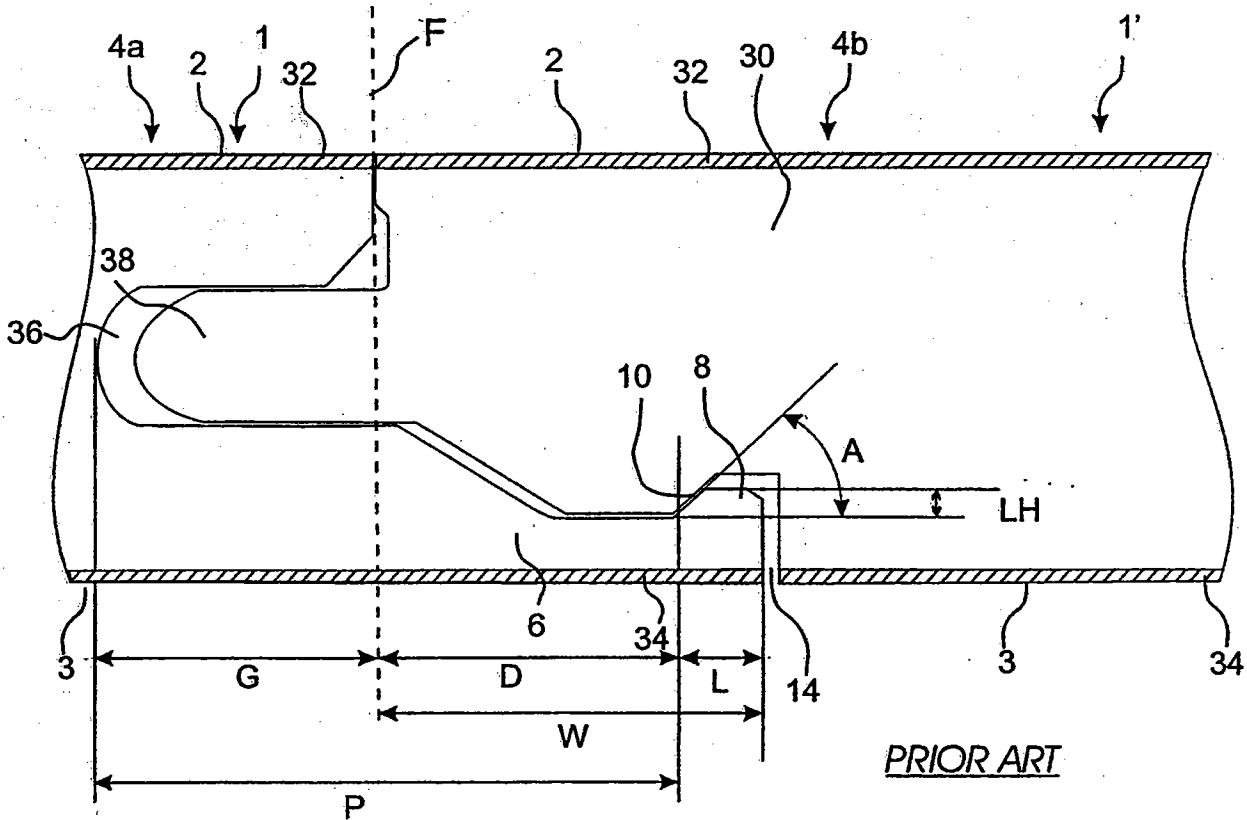

PRIOR ART

Fig. 7

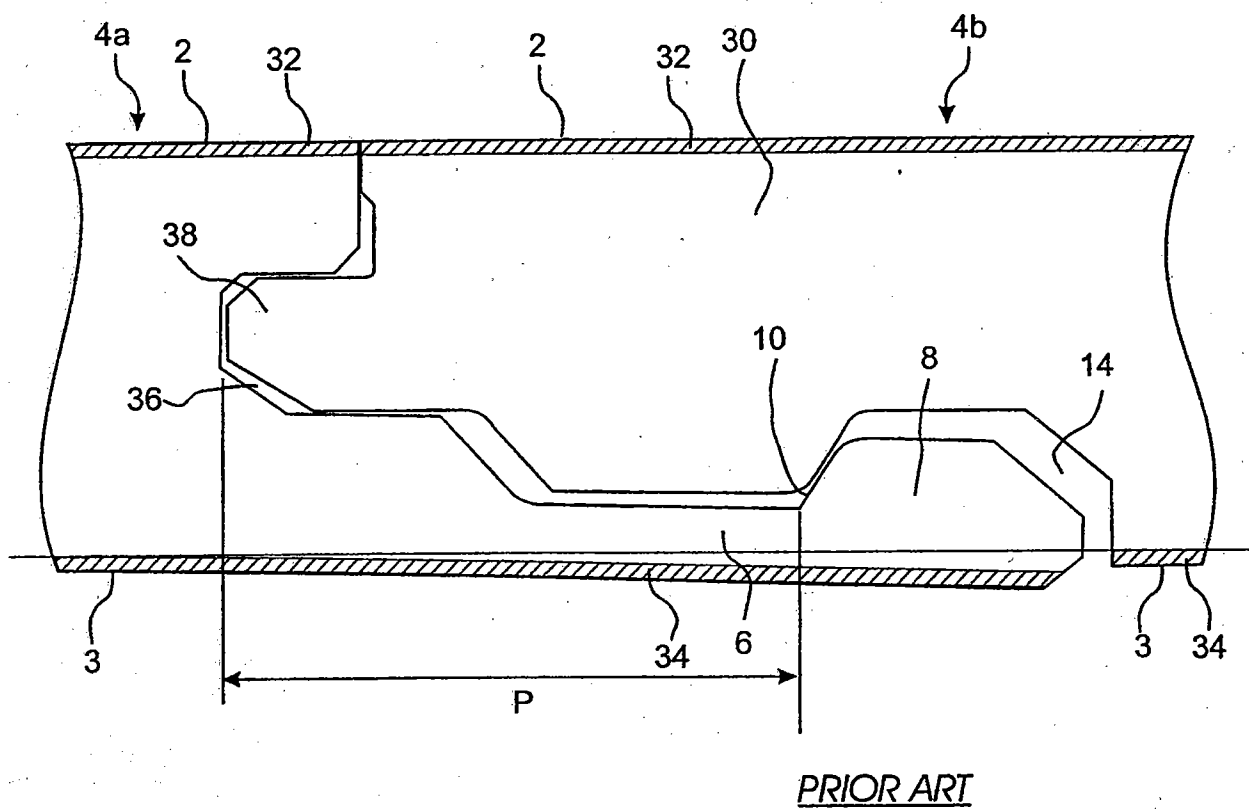
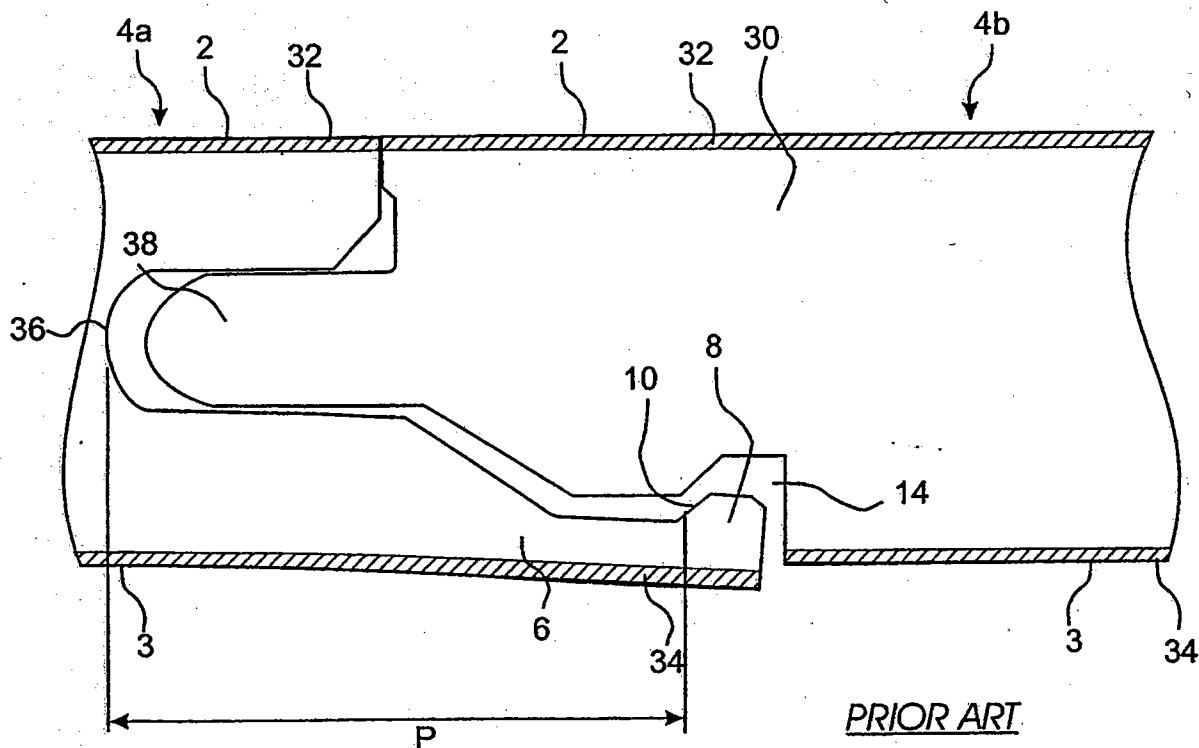

Fig. 8



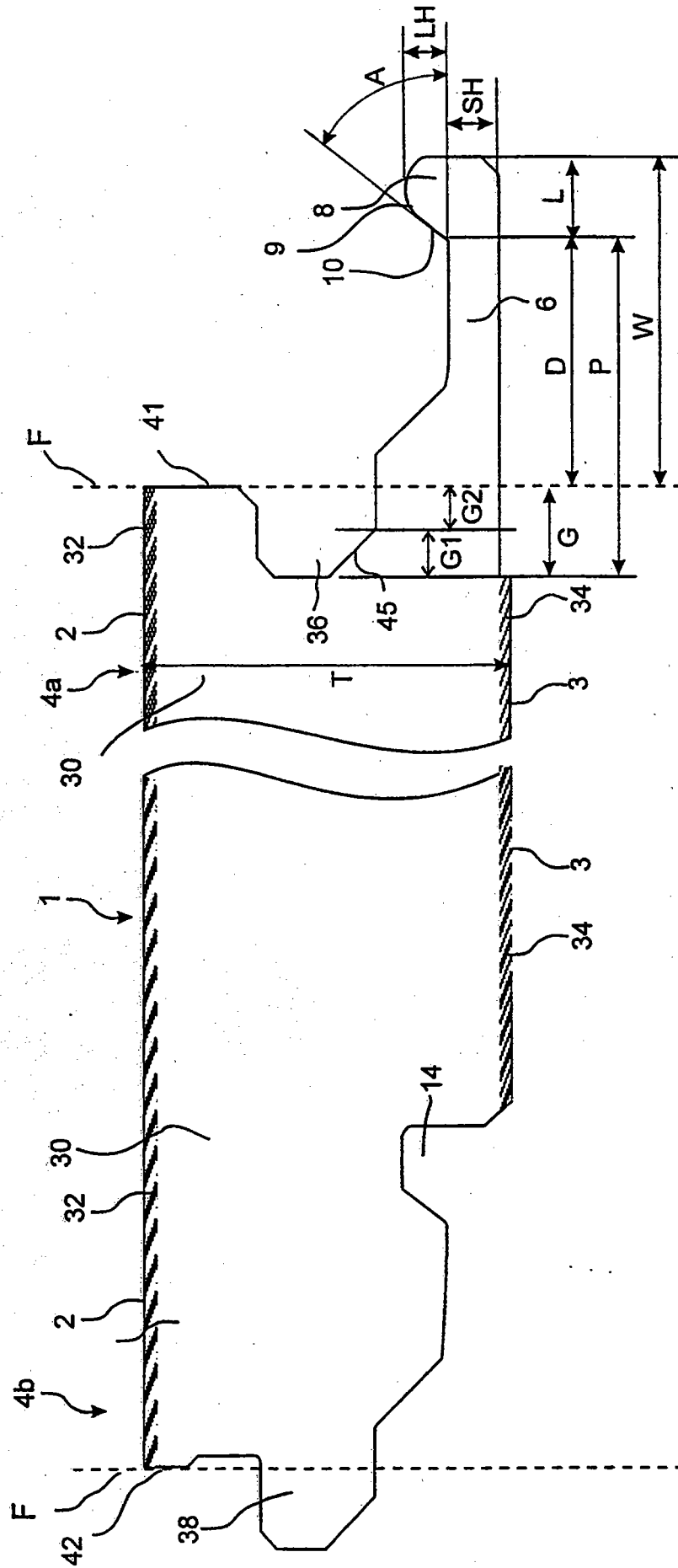

Fig. 9

Fig. 10

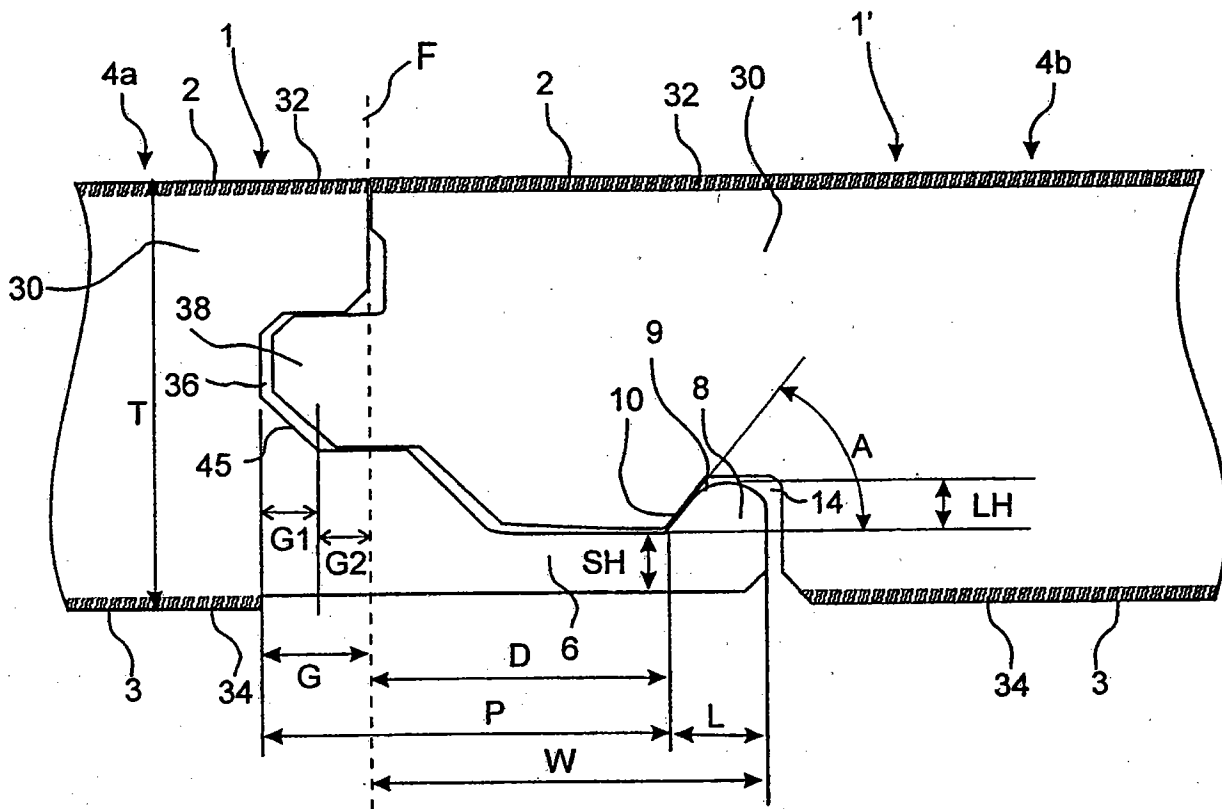

Fig. 11

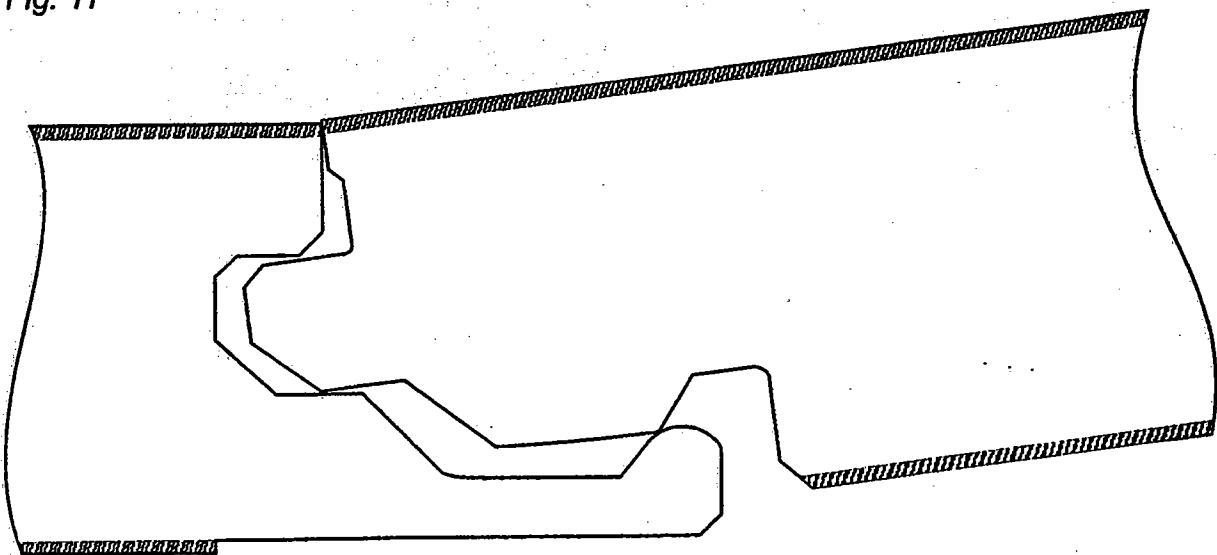

Fig. 12

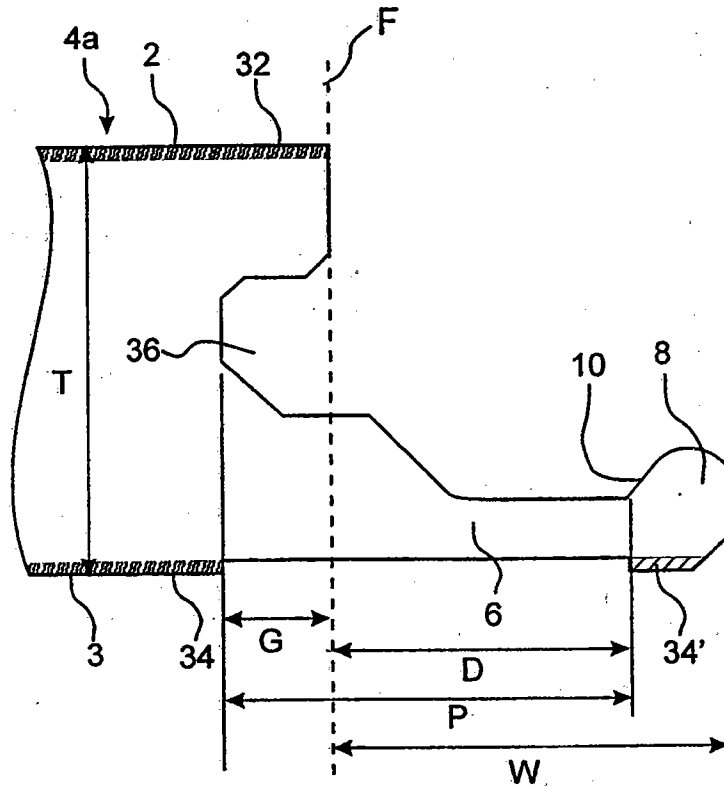
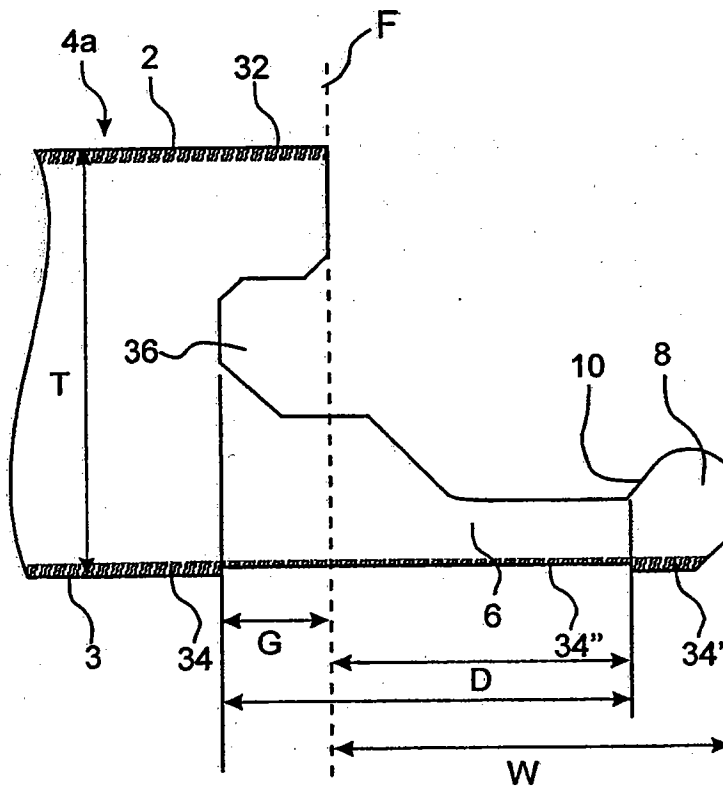

Fig. 13



INTERNATIONAL SEARCH REPORT

International application No.

PCT/SE 00/00785

A. CLASSIFICATION OF SUBJECT MATTER

IPC7: E04F 15/04

According to International Patent Classification (IPC) or to both national classification and IPC

B. FIELDS SEARCHED

Minimum documentation searched (classification system followed by classification symbols)

IPC7: E04F, B32B, B27M

Documentation searched other than minimum documentation to the extent that such documents are included in the fields searched

SE,DK,FI,NO classes as above

Electronic data base consulted during the international search (name of data base and, where practicable, search terms used)

C. DOCUMENTS CONSIDERED TO BE RELEVANT

Category*	Citation of document, with indication, where appropriate, of the relevant passages	Relevant to claim No.
Y	WO 9747834 A1 (UNILIN BEHEER B.V.), 18 December 1997 (18.12.97), page 18, line 10 - line 15, detail 58 --	1-35
Y	WO 9217657 A1 (LINDAL, W.), 15 October 1992 (15.10.92), page 3, line 1 - line 15; page 12, line 2 - line 6 --	1-35
Y	EP 0849416 A2 (MARGARITELLI ITALIA S.P.A.), 24 June 1998 (24.06.98), column 3, line 6 - line 10, detail 3 --	1-35

 Further documents are listed in the continuation of Box C. See patent family annex.

* Special categories of cited documents:

- "A" document defining the general state of the art which is not considered to be of particular relevance
- "E" earlier document but published on or after the international filing date
- "L" document which may throw doubts on priority claim(s) or which is cited to establish the publication date of another citation or other special reason (as specified)
- "O" document referring to an oral disclosure, use, exhibition or other means
- "P" document published prior to the international filing date but later than the priority date claimed

"T" later document published after the international filing date or priority date and not in conflict with the application but cited to understand the principle or theory underlying the invention

"X" document of particular relevance: the claimed invention cannot be considered novel or cannot be considered to involve an inventive step when the document is taken alone

"Y" document of particular relevance: the claimed invention cannot be considered to involve an inventive step when the document is combined with one or more other such documents, such combination being obvious to a person skilled in the art

"&" document member of the same patent family

Date of the actual completion of the international search

25 August 2000

Name and mailing address of the ISA/
Swedish Patent Office
Box 5055, S-102 42 STOCKHOLM

Date of mailing of the international search report

130 -08- 2000

Authorized officer

Örjan Nylund / MRo
Telephone No. +46 8 782 25 00

INTERNATIONAL SEARCH REPORT

International application No.

PCT/SE 00/00785

C (Continuation). DOCUMENTS CONSIDERED TO BE RELEVANT

Category*	Citation of document, with indication, where appropriate, of the relevant passages	Relevant to claim No.
Y	US 4471012 A (T.V. MAXWELL), 11 Sept 1984 (11.09.84), column 3, line 43 - line 58 --	1-35
Y	US 5474831 A (R. NYSTROM), 12 December 1995 (12.12.95), figure 5, details 15,16 -- -----	1-35

INTERNATIONAL SEARCH REPORT

International application No.
PCT/SE00/00785

Box I Observations where certain claims were found unsearchable (Continuation of item 1 of first sheet)

This international search report has not been established in respect of certain claims under Article 17(2)(a) for the following reasons:

1. Claims Nos.:
because they relate to subject matter not required to be searched by this Authority, namely:

2. Claims Nos.:
because they relate to parts of the international application that do not comply with the prescribed requirements to such an extent that no meaningful international search can be carried out, specifically:

3. Claims Nos.:
because they are dependent claims and are not drafted in accordance with the second and third sentences of Rule 6.4(a):

Box II Observations where unity of invention is lacking (Continuation of item 2 of first sheet)

This International Searching Authority found multiple inventions in this international application, as follows:

Claim 36 is considered to lack unity of invention towards each of the claims

.../...

1. As all required additional search fees were timely paid by the applicant, this international search report covers all searchable claims.
2. As all searchable claims could be searched without effort justifying an additional fee, this Authority did not invite payment of any additional fee.
3. As only some of the required additional search fees were timely paid by the applicant, this international search report covers only those claims for which fees were paid, specifically claims Nos.:

4. No required additional search fees were timely paid by the applicant. Consequently, this international search report is restricted to the invention first mentioned in the claims; it is covered by claims Nos.:

Remark on Protest

- The additional search fees were accompanied by the applicant's protest.
 No protest accompanied the payment of additional search fees.

INTERNATIONAL SEARCH REPORT

International application No.
PCT/SE00/00785

Claim 1, which refers to a locking system for mechanical connection of floor panels.

Claim 22, which refers to a floor panel provided with the locking system.

Claim 24, which refer to a method for mechanical connection of floor panels.

The independent claims 1, 22, 24 lacks corresponding special technical features according to the characterising part of claim 36. Therefore, claim 36 is considered to lack unity of invention.

INTERNATIONAL SEARCH REPORT
Information on patent family members

08/05/00

International application No.

PCT/SE 00/00785

Patent document cited in search report			Publication date	Patent family member(s)	Publication date	
WO	9747834	A1	18/12/97	AU	713628 B	09/12/99
				AU	3256997 A	07/01/98
				BE	1010339 A	02/06/98
				BE	1010487 A	06/10/98
				BG	62216 B	31/05/99
				BG	102230 A	30/09/98
				BR	9702325 A	09/03/99
				CA	2226286 A	18/12/97
				CN	1195386 A	07/10/98
				CZ	9800391 A	12/08/98
				DE	29710175 U	14/08/97
				EP	0843763 A	27/05/98
				HU	9901996 A	28/10/99
				JP	11510869 T	21/09/99
				NO	980569 A	10/02/98
				PL	324923 A	22/06/98
				SI	9720009 A	31/08/98
SK	16398 A	09/09/98				
US	6006486 A	28/12/99				
WO	9217657	A1	15/10/92	AU	1870192 A	02/11/92
				CA	2107465 A	02/10/92
				EP	0585410 A	09/03/94
				GB	2269839 A,B	23/02/94
				GB	2279380 A,B	04/01/95
				GB	9415683 D	00/00/00
				JP	6506277 T	14/07/94
				US	5475960 A	19/12/95
EP	0849416	A2	24/06/98	IT	1286998 B	24/07/98
				IT	AN960034 A,U,V	07/04/98
US	4471012	A	11/09/84	NONE		
US	5474831	A	12/12/95	AU	4674293 A	31/01/94
				CA	2140022 A	20/01/94
				EP	0651841 A	10/05/95
				WO	9401632 A	20/01/94